



# A Special Message To Our Customers

---

*Dear Valued Customer,*

***Thank you for choosing Capital's Performance Series™ cooking equipment. Because of the unique features found in our appliances, we recommend that you take the time to read this entire booklet before using your product. In it you will find valuable information on how to safely operate and maintain your appliance for years of enjoyable cooking.***

*Like you, we are cooking enthusiasts. We are passionate about our cuisine and about the appliances we create. We also understand that questions arise from time to time, so we want to make it easy for you to find the answers. That's why we pride ourselves on superior customer service and work harder to respond to your needs quickly and efficiently.*

*A Customer Service representative is always just a phone call away. You can reach us at 1.866.402.4600; by e-mail at [customerservice@capital-cooking.com](mailto:customerservice@capital-cooking.com); or by mail at 13211 Florence Ave. Santa Fe Springs, CA 90670*

*When you contact us, please make sure you have the model and your serial #'s ready. That way we can serve you better.*

*We realize you have a choice in your appliance needs so we feel honored to welcome you to the Capital family, where passion for cooking and living is a way of life.*

*Sincerely,*

**CAPITAL TEST KITCHEN SPECIALISTS**



# TABLE OF CONTENTS

---

<b>SAFETY PRECAUTIONS</b>	<b>3</b>
<b>GENERAL INFORMATION</b>	<b>4</b>
<b>MODEL</b>	<b>5</b>
<b>UNPACKING &amp; HANDLING</b>	<b>6</b>
<b>VENTILATION REQUIREMENTS</b>	<b>7</b>
<b>CABINET PREPARATION</b>	<b>8-13</b>
<b>BACKGUARD INSTALLATION</b>	<b>14</b>
<b>ELECTRICAL / GAS CONNECTIONS</b>	<b>15</b>
<b>GAS REQUIREMENTS</b>	<b>16</b>
<b>TEST AND ADJUSTMENTS</b>	<b>17</b>
<b>INSTALLER FINAL CHECKLIST</b>	<b>18</b>
<b>HOW TO OBTAIN SERVICE</b>	<b>19</b>
<b>WARRANTY</b>	<b>20</b>
<b>NOTES</b>	<b>21</b>

# SAFETY PRECAUTIONS

---

## IMPORTANT INSTALLATION INFORMATION

1. Before beginning, please read these instructions completely and carefully.
2. Do not remove permanently affixed labels, warnings, or plates from product.
3. Please observe all local and national codes and ordinances.
4. Please ensure that this product is properly grounded.

### NOTE:

To eliminate the risk of accidental fire or burns, cabinet storage located above the units should be avoided. Check local building codes for the proper method of wok installation. Local codes vary. Installation, electrical connections, and grounding must comply with all applicable codes. In the absence of local codes, the wok should be installed in accordance with the National Fuel Gas Code ANSI Z223.1-1988 and National Electrical Code ANSI / NFPA 70-1990.

**Verify that the wok/cooker is compatible with gas supply at the installation site before proceeding further.** Return the wok to dealer if the unit is not set for site gas supply.

#### FOR YOUR SAFETY

If you smell gas:

1. Shut off gas to appliance
2. Extinguish any open flame
3. Open cover
4. If odor continues, immediately call your gas supplier or fire department.

#### FOR YOUR SAFETY

1. Do not store or use gasoline or other flammable vapors and liquids in the vicinity of this or any other appliance.
2. An LP cylinder not connected for use shall not be stored in the vicinity of this or any other appliance.

## GENERAL INFORMATION

---

1. **WARNING:** This wok is not intended to be installed in or on a recreational vehicles and/or boats.
2. **WARNING:** Keep any electrical supply cord and the fuel supply hose (outdoor unit only) away from any heated surfaces. Keep the wok area clear and free from combustible materials, gasoline, and other flammable vapors and liquids.
3. For outdoor installations only, when the wok/cooker is not in use the gas supply must be turned off at the LP gas supply cylinder.
4. The pressure regulator and hose assembly (outdoor unit only) supplied with the wok must be used. Replacement pressure regulators and hose assemblies must be those specified by the manufacturer.
5. Finding a leak is not a “do it yourself procedure. Some leaks can only be found with the burner control in the “on” position and this must be done by a qualified technician.
6. The LP supply cylinder to be constructed and marked in accordance with the specifications for LP gas cylinders of the U.S. Department of Transportation (DOT) or the National Standard of Canada, CAN/CSA\_B339, Cylinders, Spheres, and Tubes for the Transportation of Dangerous Goods.
7. Gas Manifold Pressure:

**FOR OUTDOOR INSTALLATION ONLY**

Natural Gas: 4” w.c.

LP/Propane: 10” w.c.

**FOR INDOOR INSTALLATION ONLY**

Natural Gas: 5” w.c.

LP/Propane: 10” w.c.

8. **IMPORTANT:** Save these instructions for the local Gas Inspector’s use.
9. **INSTALLER:** Please leave these Installation Instructions with the unit for the owner.
10. **OWNER:** Please retain these Installation Instructions for future reference.

# MODEL

---

24" PS Wok Outdoor and 24" GRT Wok Indoor



# UNPACKING AND HANDLING

---

## INDOOR and OUTDOOR

### STEP 1:

#### PLACING THE WOK

**NOTE:** *If a solid side cabinet wall exists on one or both sides, you will need to notch the front corner of the cabinet to match the counter top notch and to provide clearance for the wok front (see page 8).*

---

#### **CAUTION:**

*Proper equipment and adequate manpower must be used in moving the wok to avoid personal injury or damage to the unit.*

#### **ANCHORING THE WOK**

The woks have a shipping weight of approximately 90 pounds. Remove all packing materials and the outer carton from the shipping base. The wok is held to the skid by 2 brackets. After removing the brackets, the wok must be lifted and removed from the skid.

The wok should be moved as close as possible to its final location. Electric and gas connections should be made per steps 5 & 6 (pgs 15 & 16) and the backguard installed per step 4 (pg. 14) before the wok is placed in its final position.

# VENTILATION REQUIREMENTS

---

## STEP 2:

A suitable exhaust hood must be installed above the wok. The following chart indicates the Minimum blower capacity recommended for hood ventilation.

VENTILATION UNIT	STANDARD COUNTER INSTALLATION RECOMMENDATIONS	ISLAND INSTALLATION RECOMMENDATIONS
HOOD	24" Deep x Unit Width	30" Deep x 36" at Bottom
BLOWER	<b>24" WOK</b> 1200 CFM	1200 CFM

### **CAUTION:**

---

***Ventilation hoods and blowers are designed for use with single wall Ducting,*** however, some local building codes or inspectors may require double wall ducting. Consult local building codes and/or local agencies, before starting to ensure that the hood and duct installation will meet local requirements.

A variable speed Hood blower can reduce noise and loss of air conditioned household air when maximum ventilation is not required. Normally, the maximum blower speed is only required when the wok burner is in operation. For best smoke elimination, the lower edge of the hood should be installed a minimum of 36" above the wok cooking surface, (step 3 pg. 8). If the hood contains any combustible materials (i.e. wood covering) it must be a minimum of 36" above the cooking surface. Due to a high volume of ventilation air, a source of outside replacement air is recommended. This is particularly important for tightly sealed and insulated homes. A reputable heating and ventilating contractor should be consulted.

# CABINET PREPARATION

## STEP 3:

- 1) To ensure professional results, the cabinet and countertop openings should be prepared by a qualified cabinet worker. We recommend having the wok available before cutting the opening for a more accurate measurement and verification of all installation dimensions.
- 2) The clearance shown in fig. 5 pg.13 is required for all types of backguard installations.
- 3) The wok is designed to hang from the countertop from its side flanges. The countertop must be strong enough to support this heavy wok. It may be necessary to add a supporting cleat along each side or another form of support such as a 2" x 4" corner brace on each side or a deck to set the wok on. See Fig. 1.
- 4) The wok can be installed in various positions with the front either flush or projecting, depending on the countertop depth. See Fig. 2 & Fig. 4 (wok side view).
- 5) Establish the centerline of the desired wok location. It should be the same as the center of the overhead ventilation hood.

### **NOTE: FOR OUTDOOR WOK.**

check the vent hood installation instructions for enclosed ventilation hood.

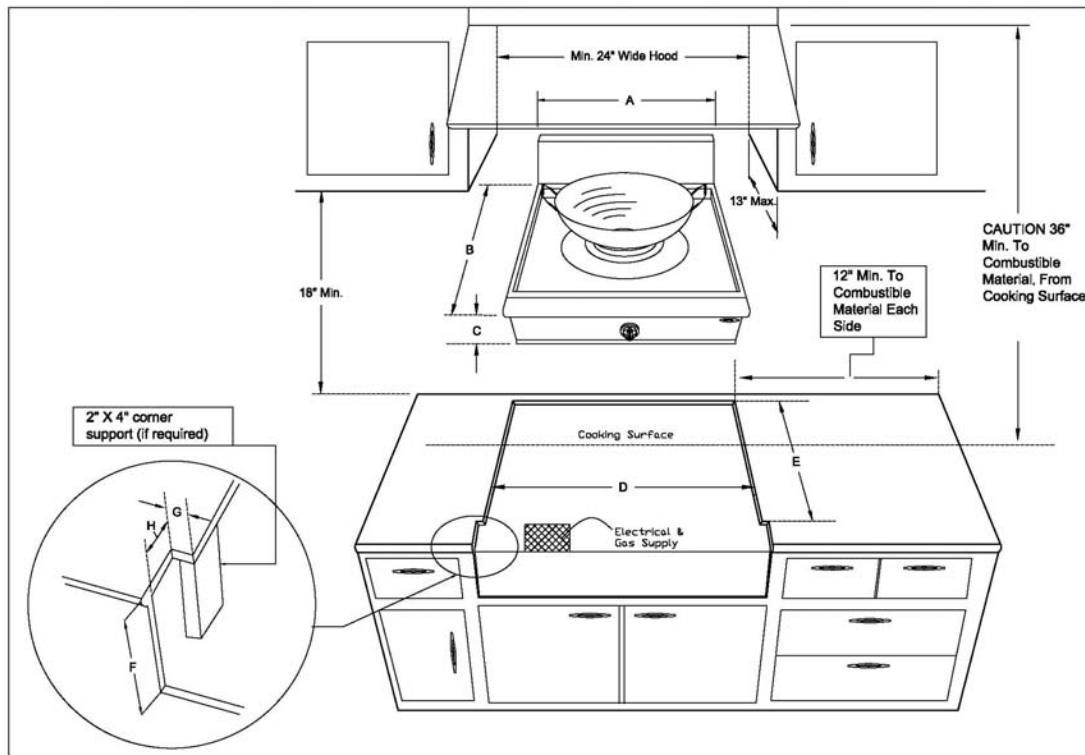

FIG 1

DIMENSIONS	A	B	C	D	E	F	G	H
PSQ 24 WOK	24	27 1/8	8 1/4	23	23 1/8	7 1/2	7/16	2-1/2
GRT 24 WOK	24	26 5/8	8 1/4	23	23 1/8	7 1/2	7/16	2-1/2

## CABINET PREPARATION

---

### STEP 3: (CONTINUED)

6) Prepare cabinet cutouts for the following installations based upon the referenced diagrams:

- Standard counter top installation, see Fig. 5A
- Deep counter or island installation, see Fig. 5B

**NOTE:** *If the deck is used, the sides or bottom of the cutout may be solid combustible or non-combustible material. If the bottom is solid, provide a 6" x 6" cutout in the left rear corner for the gas inlet and power cord clearance.*

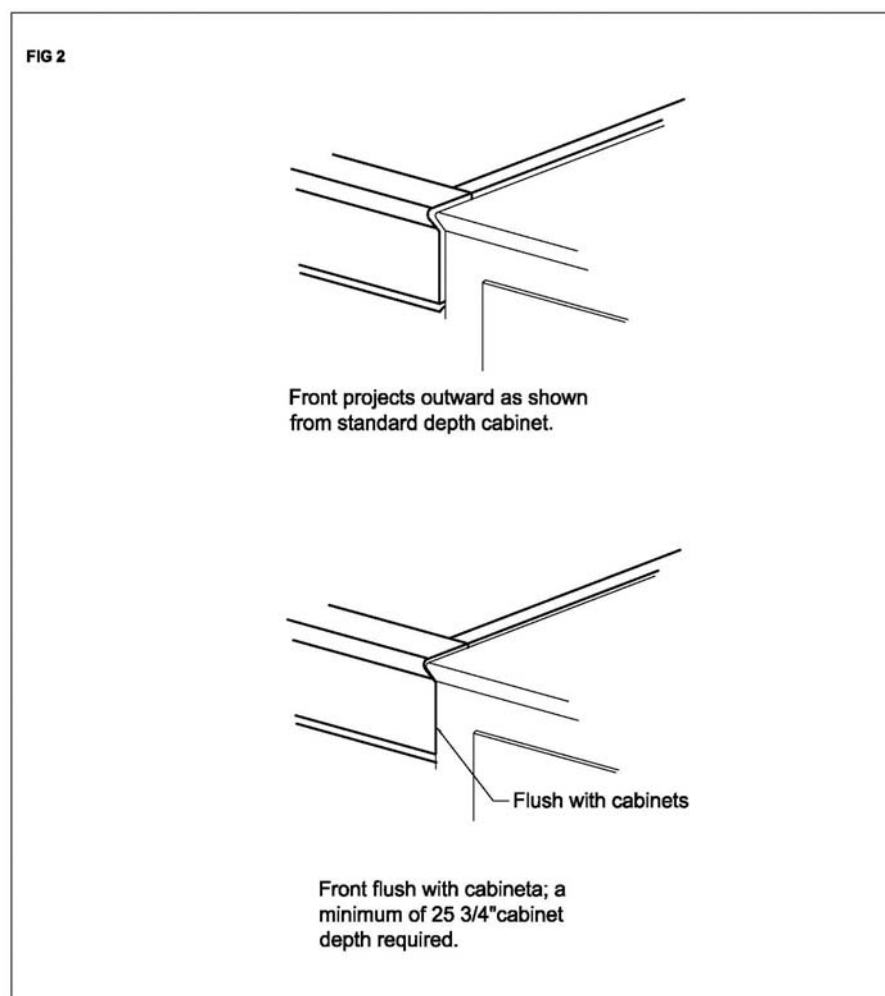

# CABINET PREPARATION

---

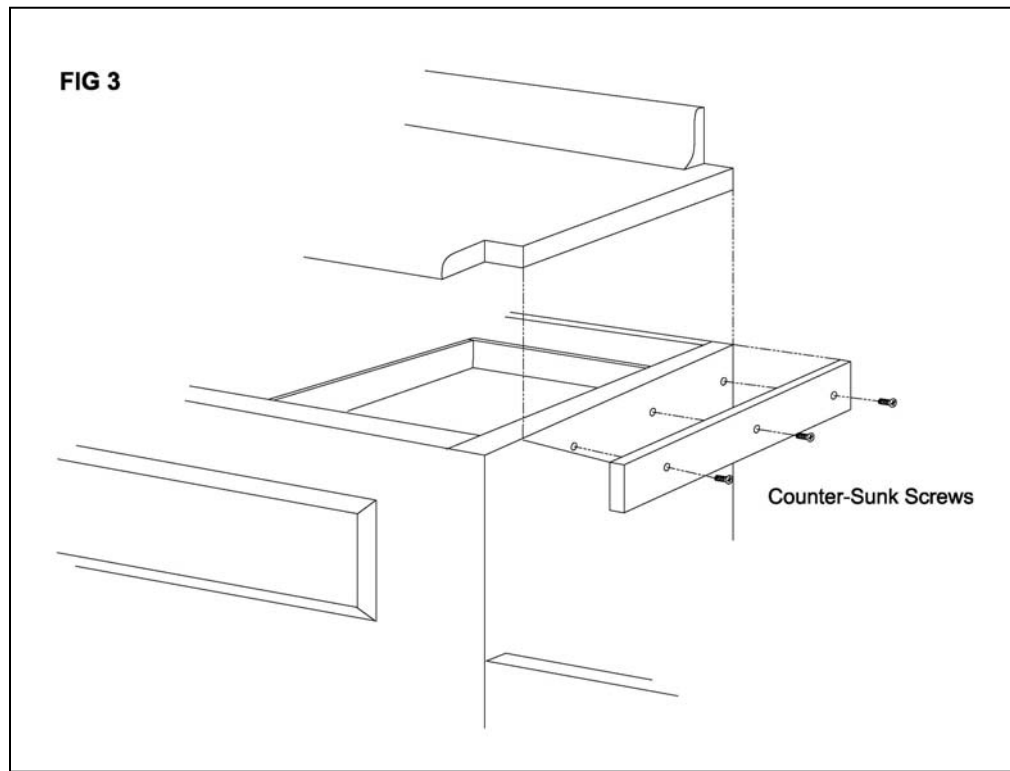



# CABINET PREPARATION – OUTDOOR INSTALLATION

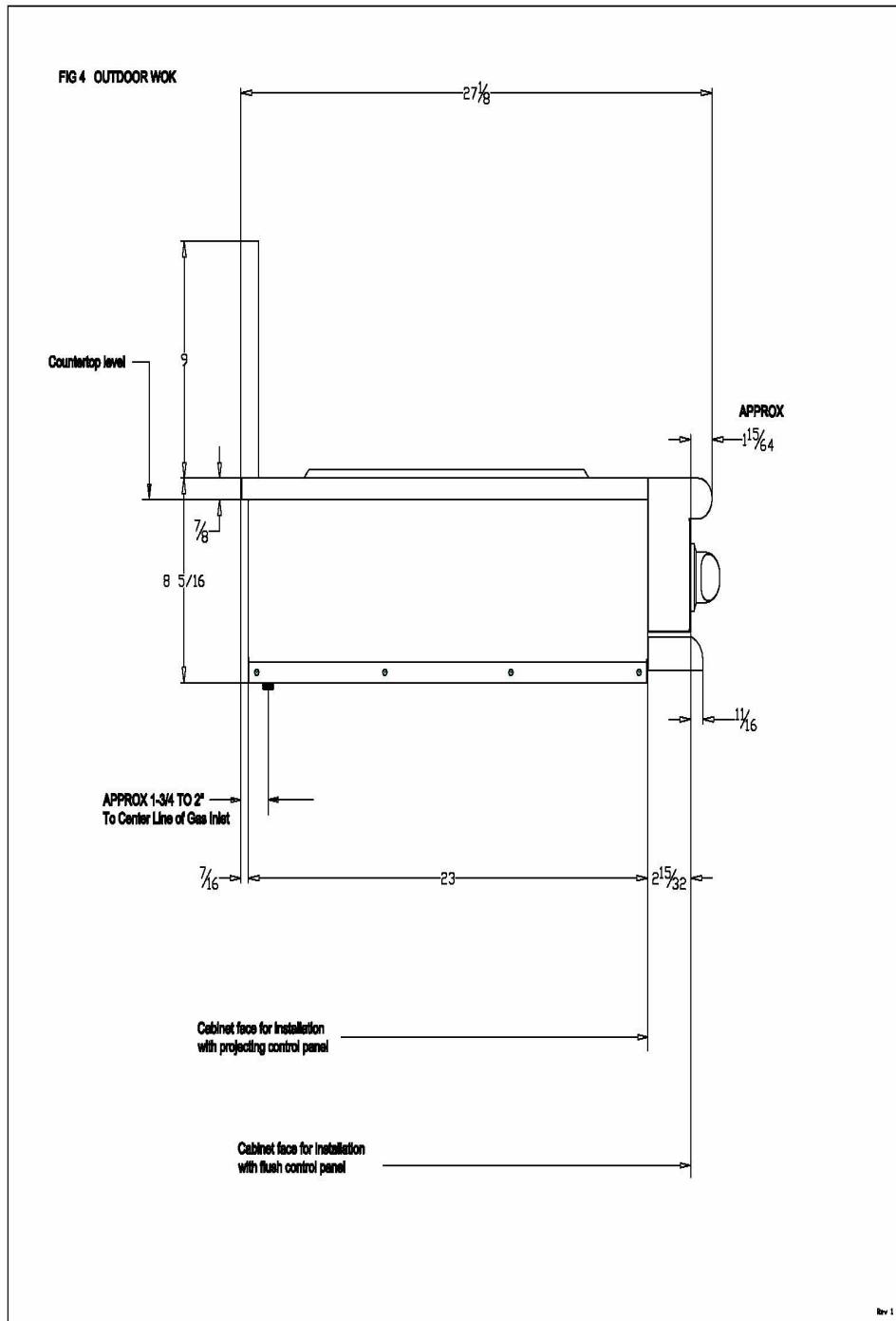

# CABINET PREPARATION

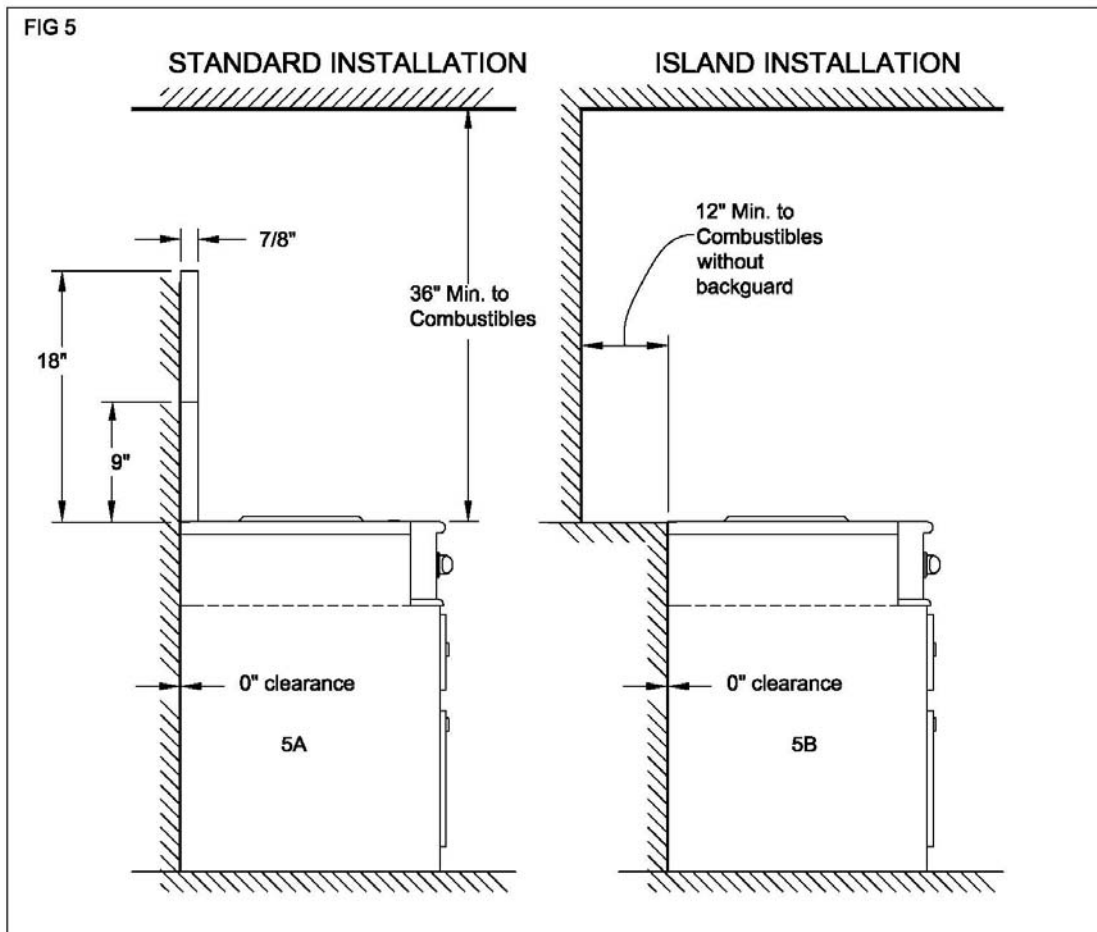

# BACKGUARD INSTALLATION

---

## STEP 4:

### BACKGUARD KITS:

The back guard is located as shown in Fig. 6. Secure the backguard to the wall behind the wok. Specific instructions for installation of the high or low backguards can be found packaged with the backguard.

The back guard must be installed when there is less than a 12" clearance between combustibles and the back of the wok (above the cooking surface, see Fig. 5, Page 11).

## INDOOR AND OUTDOOR BACKGUARD MOUNTING

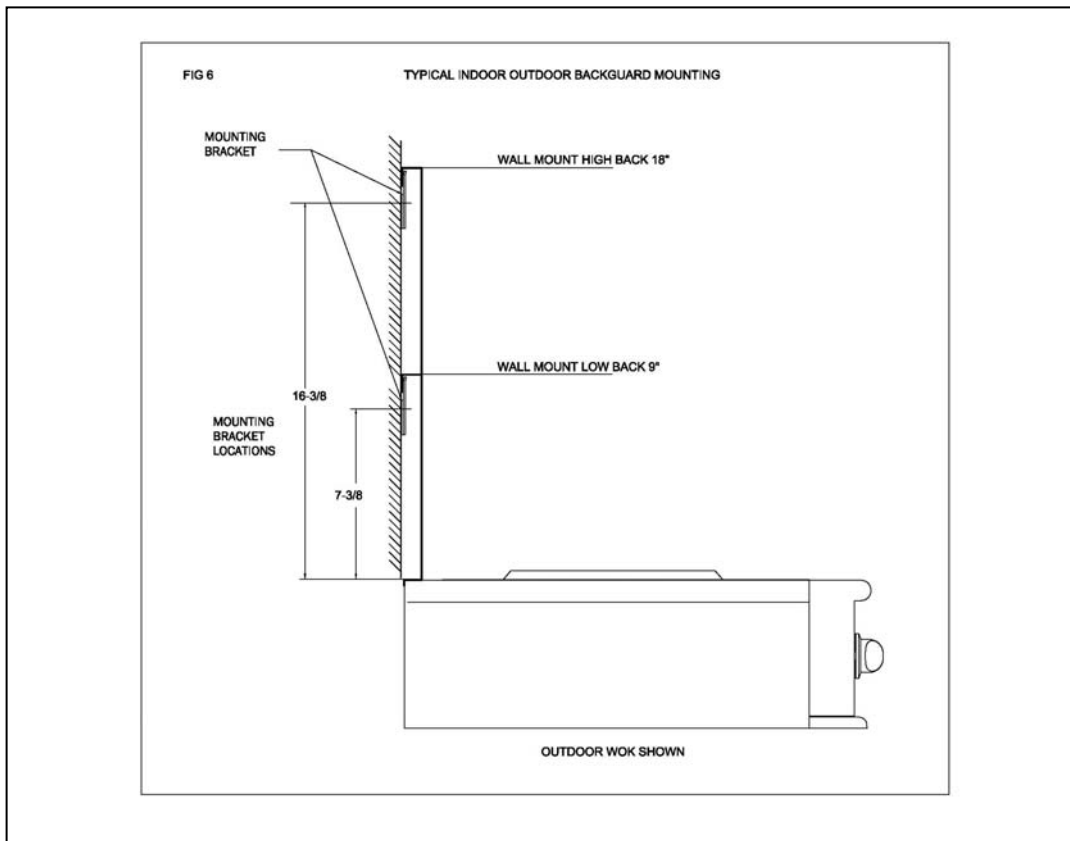

# ELECTRICAL / GAS CONNECTIONS

## STEP 5:

### ELECTRICAL CONNECTIONS

#### Wok Power Requirements

- 120 VAC, 60Hz, single phase 15 Amp circuit.

Always disconnect electric supply cord from the wall out or service disconnect before servicing this appliance. Observe all governing codes and ordinances when grounding, in absence of which, observe National Electrical Code ANSI / NFPA No. 70-1990

#### RECOMMENDED GROUNDING METHOD

This appliance is factory equipped with a power supply cord with a three-prong grounding plug (with polarized parallel blades). It must be plugged into a mating grounding type receptacle connected to a correctly polarized 120 Volt circuit. If the circuit does not have a grounding type receptacle, it is the responsibility and obligation of the installer to have the existing receptacle changed to a properly grounded and polarized receptacle in accordance with all applicable local codes and ordinances by a qualified electrician. In the absence of local codes and ordinances, the receptacle replacement shall be in accordance with the National Electrical Code.

- The third prong should not, under ANY circumstances, be cut or removed.

#### GAS REQUIREMENTS

Verify the type of gas supplied to the location. The wok is shipped from the factory set up and adjusted for natural gas or LP (propane), depending on specific model ordered. **Conversion of gas from LP to NG or NG to LP is not permissible.**

#### NATURAL GAS

- Connection: 1/2" N.P.T., Minimum 5/8" dia flex line ■ Supply Pressure: 6" to 9" W.C.

#### LP GAS

- Connection: 1/2" N.P.T., Minimum 5/8 dia. Flex line. ■ Supply Pressure: 11" to 14" W.C.  
A regulator is required at the LP source to provide a maximum of 14"W.C. to the wok regulator.

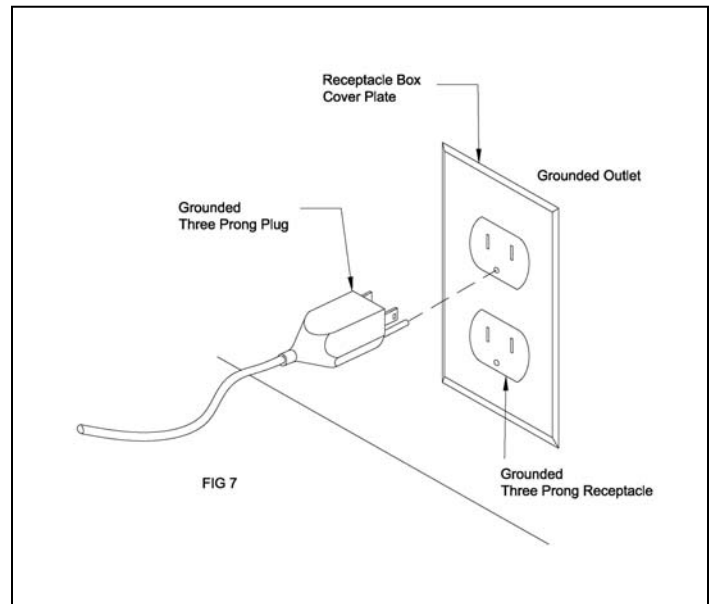

# HOOK-UP TO GAS SUPPLY

## STEP 6:

### HOOK-UP

A manual shut-off valve must be installed external to the appliance, in an accessible location from the front, for the purpose of shutting off the gas supply. Make sure the gas supply is turned off at the wall valve before connecting the appliance. The gas supply connections should be made by a qualified technician and in accordance with local code or ordinances. In the absence of a local code, the installation must conform to the National Fuel Gas Code ANSI 223.1-1988, latest edition.

To prepare the unit for connection to the gas supply, thread the supplied 1/2" pipe nipple into the elbow on the end of the manifold. The elbow is located inside the chassis of the unit, on the end of the manifold, facing down. See Fig. 9. It is accessible through the square cutout in the left rear corner of the chassis bottom.

Connect the outlet of the regulator to the exposed end of the nipple, connect the flex line from the gas supply to the inlet side of the regulator. Apply Teflon tape to threads

**NOTE:** The arrow on the regulator indicating direction of gas flow should be pointing towards the unit. The flex line for the gas supply must be metal and be approved by an approved certifying agency (AGA, CGA, or UL.). Never use a hose made of rubber or other synthetic material, as the heat may cause the hose to melt and develop leaks.

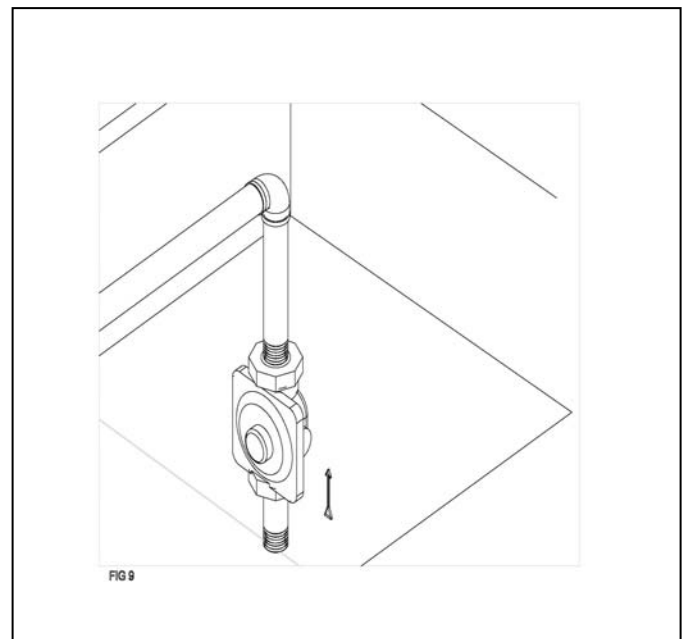
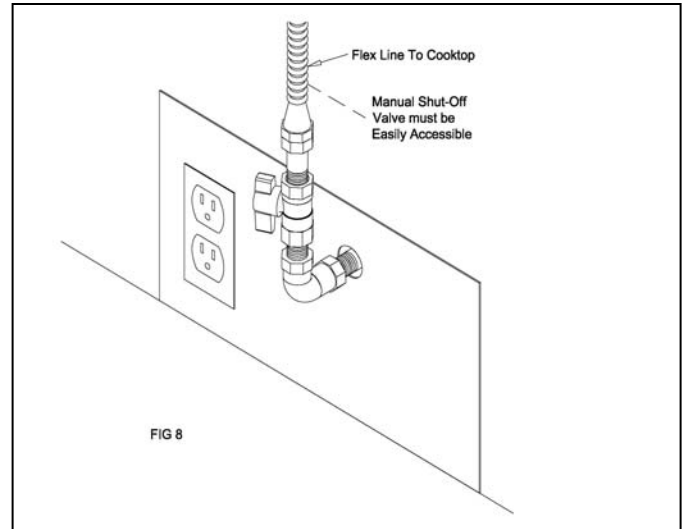

### **CAUTION:**

**The appliance must be isolated from the building's gas supply piping system by closing its individual manual shut-off valve during any pressure testing of the gas supply piping system at test pressures equal to or less than 1/2 psig (3.5kPa.) The appliance and its individual shut-off valve must be disconnected from the gas supply piping system during any pressure testing of the system at the test pressure in excess of 1/2 psig (3.5kPa.). When checking the manifold gas pressure, the inlet pressure to the regulator should be at least 7.0" W.C. for natural gas or 12.0" for LP.**

## TEST AND ADJUSTMENTS

---

### STEP 7:

#### **CAUTION:**

*For warranty coverage, Capital Cooking requires that burner adjustments be made by a qualified technician at the time of installation. Extreme care should be used when adjustments are made after installation. Improper or lack of adjustments will void your warranty.*

### **SURFACE BURNERS**

The surface burners are not adjustable. Proper operation is achieved when the correct orifices for gas supply are installed at the factory, based on model ordered.

#### **INDOOR UNITS ONLY**

- If the surface burner does not ignite, check the spark igniter by listening for a clicking sound. If you do not hear the igniter click, turn off the burner. Check for a tripped circuit breaker, blown fuse, or poor wire connection to the igniter.

#### **OUT DOOR UNITS ONLY**

- If the gas igniter does not glow orange within 30-40 seconds or if the smell of gas is detected without the presence of flames, turn off the burner immediately. Check for a tripped circuit breaker, blown fuse, or poor wire connection to the igniter.

### **TO CLEAN EXTERIOR SURFACES**

The stainless steel surfaces may be cleaned by wiping with a damp soapy cloth. Any mild glass cleaner will remove fingerprints and smears. Do not use steel wool as it will scratch this surface. Small scratches may be removed by lightly sanding with the grain using SCOTCH BRIGHT.

# INSTALLER FINAL CHECKLIST

---

## GENERAL

- Placement of unit.
- Specified clearance maintained to cabinet surfaces.
- Unit level – front to back, side to side.
- All packaging material and tie straps removed, drip pans clean and empty.
- Backguard attached if there is less than 12” clearance above the cooking surface to combustibles behind unit.

## ELECTRICAL

- Receptacle with 15 ampere over-current protection is provided for service cord connection.
- Adequate ground connection.

## GAS SUPPLY

- Connection: 1/2 NPT with a minimum 5/8” diameter metal flex line.
- Site gas supply is compatible with wok model, & sufficient pressure is available (see gas requirements pg. 12)
- Manual gas shut-off valve installed in accessible location.
- Unit tested and free of gas leaks.

## OPERATION

- All internal packing materials removed.
- Bezel centered on burner knob and knob turn freely.
- Burners lights satisfactorily.
- Burner grate correctly positioned, level, and do not rock.

## SERVICE INFORMATION

---

Before contacting customer service:

- Check if the circuit breaker tripped or the fuse is blown
- Is there a power outage in your area?

If none of the above has occurred, contact our customer service department at 1.866.402.4600

Before you call for service, please have the following information available:

- Model Number
- Serial Number
- Date of installation
- A brief description of the problem

Your satisfaction is our top priority. If the problem persists, or is not resolved to your satisfaction by our service consultant, please write to us or fax us a letter at:

**Capital Cooking Equipment Inc.**  
Attention: Customer Service Manger  
13211 E. Florence Ave.  
Santa Fe Springs CA  
90670  
USA

Fax: (562) 903-1167.

Email: [customerservice@capital-cooking.com](mailto:customerservice@capital-cooking.com)

# WARRANTY

---

- One (1) year full parts and labor covers the entire unit.

## **WILL PAY FOR:**

All repair labor and parts found to be defective or due to material workmanship for one (1) full year “IN HOME” warranty. This does not apply if the unit was subjected to other than normal household use. An Authorized Factory Agent must provide Service during normal working hours. No charges will be made for repair or replacement at the location of original installation or factory for parts returned pre-paid, through the dealer and claimed within the warranty period, and found to be defective by Capital. All claims, regardless of warranty or non-warranty must be documented with photos and detailed description and/or narrative of the problem.

Replacement will be F.O.B our factory. The company will not be liable for transportation costs, labor cost or export duties. This warranty shall not apply, nor can we assume responsibility for damage that might result from failure to follow manufacturer’s instructions or local codes where the appliance has been tempered with or altered in any way or which, in our judgment, has been subjected to misuse, negligence, or accident. Implied warranty shall not extend beyond the duration of this written warranty. This warranty is in lieu of all warranties, expressed or implied and all other obligations or liability in connection with the sale of this product.

## **WILL NOT PAY FOR:**

- Installation or start-up.
- Shipping damage.
- Service by an unauthorized agency.
- Use of unauthorized parts.
- Service during hours other than normal working hours.
- Improper installation.
- Service visit to teach you how to operate the appliance, correct the installation, reset circuit breakers or replace fuses.
- Repair other than normal household use.
- Damage caused by accident, abuse, alteration, misuse, incorrect installation or installation not in accordance with local codes.
- Unit installed in non-residential application.

**This warranty applies to appliances used in residential application only. It does not cover their use in commercial situations (commercial situations include but are not limited to restaurants, public parks and recreation areas, any area where units are exposed to multiple users, public cooking areas, etc.) This warranty is for products purchased and retained in the 50 States of the U.S.A, the District of Columbia and Canada. This warranty applies even if you should move during the warranty period. Should the original purchaser sell the appliance during the warranty period, the new owner continues to be protected until the expiration date of the original purchaser’s warranty period. This warranty gives you the specific legal rights. You may also have other rights, which vary from State to State.**

## NOTES

---



**GRT24WK AND PSQ24WK  
INSTALLATION MANUAL  
24 WOK MODEL**

